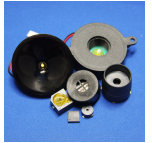

# CT12P-30T400-5

 Rev. 0-2025  
 RoHS3 & REACH  
 Piezoelectric Sound Transducers

## Operating Characteristics

### ELECTRICAL

Rated Voltage	3 Vp-p
Max Operating Voltage	30 Vp-p
Max Current at V Rated	2 mA
Capacitance	12,000 pF ± 30 % 120 Hz

### ACOUSTIC

Min SPL at V Rated	75 dB
Test Conditions	10 cm
$f_0$	4,000 Hz

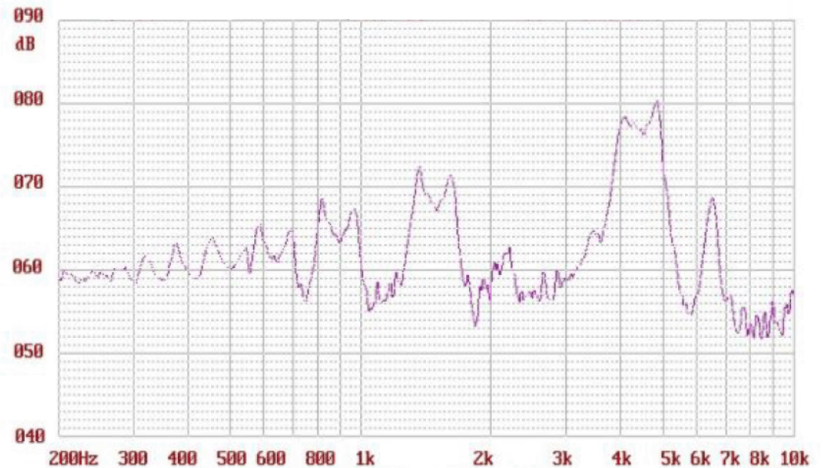

## Physical Characteristics

### MATERIALS

Housing	PBT
Diaphragm	Brass
PC Pin	Tin Plated Copper

### TEMPERATURE RANGES

Operating	-20 to +80 °C
Storage	-40 to +85 °C

Weight	0.7 g
--------	-------

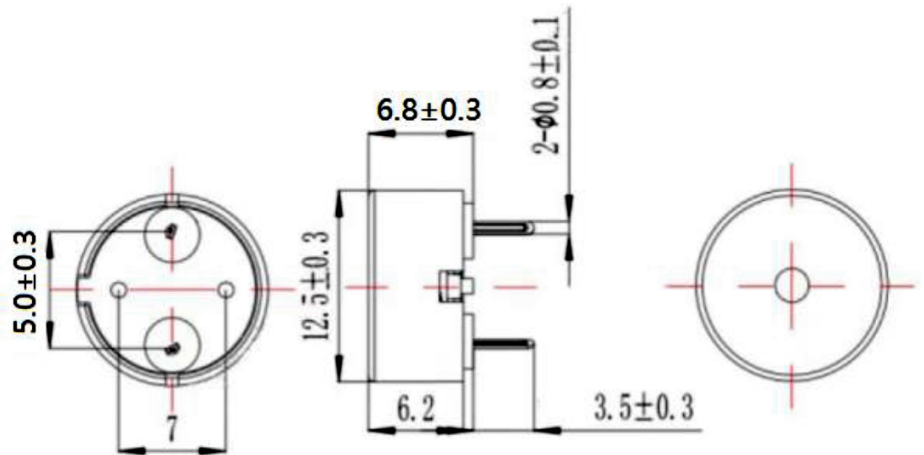
 General tolerance =  $\pm 0.5$  mm and all measurements in mm unless otherwise noted.

Revision	Description	By	Date
0-2025	Original Specification	KG	2025-12-08

Warranty: For a period of one (1) year from date of shipping under normal operations conditions. This warranty does not apply to products damaged through misuse, abuse, improper installation, alteration, rework, or attempt to repair.

The information contained herein is believed to be correct, but no guarantee or warranty, express or implied, with respect to accuracy, completeness or results is extended and no liability is assumed. Challenge Electronics reserves the right to make changes in any specification, data or material contained herein.