



PRODUCT INFORMATION

Abbreviated Part #:	CEMB260I-716	Revision: 2-2012
PART #:	CEMB260I176-716C400W150R	



Mechanical Buzzer

DESCRIPTION	FEATURES
Challenge Electronics Mechanical Buzzer, 41.0 mm Long, 26.4 mm ϕ Wide, I Type Housing, 17.6 mm High, 7 to 16 Vdc Operating Voltage, Continuous Tone, Medium Loud, 400 Hz. sound frequency, Wire Leads 28 AWG 150 mm Long color coded Termination, RoHS Lead Free Compliance	<ul style="list-style-type: none"> RoHS, Lead Free Compliant ISO 9001 & QS900 Certified

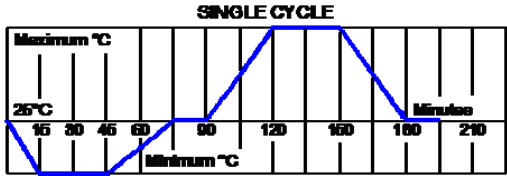

SPECIFICATIONS	
Sound Type	Continuous Rate
Operating Voltage	7 - 16 Vdc Rated Voltage 12 Vdc Maximum Current at Rated Voltage 23 mA
Sound Pressure Level	95 dB(A), at rated Voltage and 10 cm Resonant Frequency 400 \pm 100 Hz.
Operating Temperature	-20°C to + 60°C Storage Temperature -30°C to + 70°C
Termination	Wire leads, 28 AWG, UL 1007, 5.9" (150 mm) Long, Striped 0.196" (5.0 mm), Color Coded: Red = Positive, Black Stripe = Negative
Material	ABS Color White
Dimensions	Long (L) 41.0 mm Wide (W) 26.4 mm ϕ Height (H) 17.6 mm Mounting Holes distance 32.0 mm
Approximate Weight	17 grams Mounting Flange Panel with 2 screws Compliance RoHS Lead Free
Packaging	35 parts per Foam, 350 parts Stack, 700 parts per Carton.

Reliability	
Thermal Operating Temperature Test	240 hours continuous operation at Rated Power, at Maximum Rated Operating Temperature * 240 hours continuous operation at Rated Power, at Minimum Rated Operating Temperature *
Thermal Storage Temperature Test	240 hours storage at Maximum Rated Storage Temperatures * 240 hours storage at Minimum Rated Storage Temperatures *
Thermal Shock Test	(5) cycles of Minimum and Maximum Operating Temperature Each cycle shall be set per diagram below and is three (3) hours long * 
Humidity Test	240 Hours at +40°C \pm 2°C. 90-95% RH *
Operation Life Test	Must perform normal with program White Noise source at Rated Power for 100 Hours per (EIA)
Vibration Test	After parts are subjected to 2 Hours of at 1.5 mm with 10 to 55 Hz. vibration frequency to each of 3 perpendicular directions *
Termination Strength	Maximum of 9.8 N (1.0 Kg) load pull test, applied to each terminal in axial direction for 10 seconds
Drop Test	After parts are subjected to dropped naturally from 1 meter height onto the surface of 40 mm wooden board, 3 axes (X,Y,Z) directions, 3 times (9 times total) *
Reliability Test Performance *	Parts should conform to original performance within \pm 5 dB tested with Rated Power, after 3 hours of recovery period
Warranty	For a period of one (1) year from date of shipping under normal operations conditions

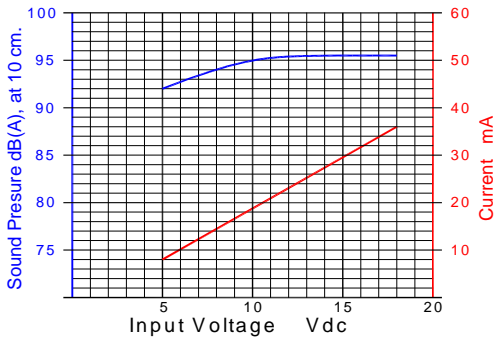
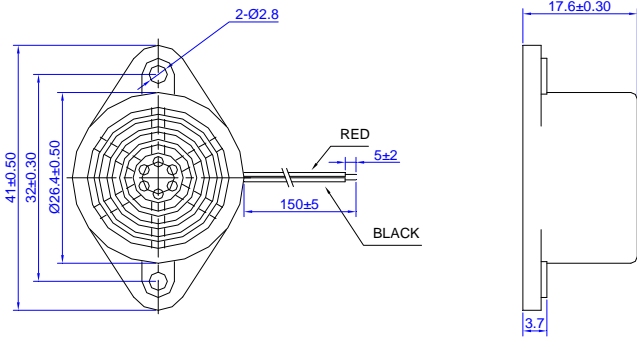
PERFORMANCE CURVE:	DIMENSIONS:
	

The information contained herein is believed to be correct, but no guarantee or warranty, express or implied, with respect to accuracy, completeness or results is extended and no liability is assumed. Challenge Electronics reserves the right to make changes in any specification, data or material contained herein.